

Cylindrical anode double layers (‘firerods’) produced in a uniform magnetic field

Tao An, R L Merlino and N D’Angelo

Department of Physics and Astronomy, The University of Iowa, Iowa City, IA
52242, USA

Received 6 April 1994, in final form 19 May 1994

Abstract. The effect of an external magnetic field on the evolution of cylindrical, luminous anode double layers (‘firerods’) from spherical ‘fireballs’ has been investigated in weakly ionized argon or xenon discharge plasmas. The ‘fireballs’ are initially produced from an additional discharge which forms when a disc electrode (3–5 cm diameter) is biased, relative to the local plasma potential, to a voltage larger than the ionization potential of the neutral gas. If a magnetic field of sufficient strength is applied in the direction normal to the disc, the fireball is transformed into an elongated magnetic field aligned luminous object which we refer to as the ‘firerod’. The dependence of the firerod length on magnetic field strength and neutral gas pressure has been studied. The formation of the firerods requires that the ions be weakly magnetized; an upper limit on the magnetic field strength also exists, beyond which they cannot be maintained. The firerods have been analysed in terms of a simple model which attempts to account for the observed dependence of their length on magnetic field and neutral gas pressure. The results of this study are relevant to the so called ‘plasma contactors’ which are used to control the potential of spacecraft in low Earth orbit.

1. Introduction

In a previous paper (Song *et al* 1991) we described an investigation of luminous, sharply defined, and nearly spherical objects (fireballs) that formed in contact with a disc electrode, biased at a positive voltage of 40–50 V and immersed in an *ummagnetized*, partially ionized Ar, Kr, or Xe plasma produced by a hot filament discharge at a gas pressure in the range of ~ 0.1 –2 mTorr. These ‘fireballs’ are maintained through ionization of the neutral gas by electrons which are accelerated at a double layer at the boundary with the surrounding plasma. They were analysed in terms of a spherical double-layer model in which ion production within the fireball due to the accelerated electron was balanced against ion losses through its surface, and it was assumed that the particle fluxes satisfied the Langmuir condition.

These anode glows have also been studied by others (Sanduloviciu and Popa 1993) who have pointed out the role of excitation as well as ionization processes in their formation. They have also been investigated in magnetized plasmas (Torvén and Andersson 1979, Andersson 1981, Fujita *et al* 1984) and in plasmas with non-uniform magnetic field configurations (Cartier and Merlino 1987, Plamondon *et al* 1988, Song *et al* 1992b). The evolution of an anode glow from an electron-collecting sheath due to an ionization-induced

instability has been studied numerically (Cook and Katz 1988).

In the present paper we describe an extension of our earlier fireball work (Song *et al* 1991, 1992a), to the case of a plasma in which a magnetic field can be applied normal to the surface of the anode disc. The strength of the magnetic field is such that the electrons are well magnetized, whereas the ions are only weakly magnetized. If a stable (spherical) fireball is present, the application of the magnetic field converts it into a luminous cylindrical object which we refer to as a ‘firerod’.

In section 2 we describe the apparatus in which the experiments were performed and the measurement techniques that were used. Section 3 contains the experimental results. In section 4 we discuss these results and describe a rudimentary model that we have developed as a first step in attempting to understand the role that the magnetic field plays in determining the behaviour of these firerods. This model is a direct extension of the one used to analyse the unmagnetized spherical fireballs. A few concluding remarks are made in section 5.

2. Experimental set-up

The experiments were performed in the device shown

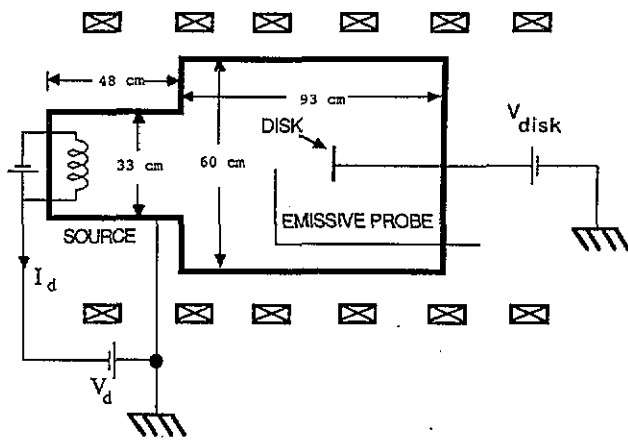

Figure 1. Schematic diagram of the discharge device. The firerods are anchored to the disc roughly in the centre of the large chamber.

schematically in figure 1. The vacuum vessel consisted of a multi-dipole source chamber and a larger main chamber, both evacuated to a base pressure $\sim 10^{-6}$ Torr. The plasma was produced by biasing a set of hot tungsten filaments in the source chamber at -60 V relative to the chamber walls. Typically the neutral gas (Ar or Xe) pressure was in the range of 5×10^{-4} – 5×10^{-3} Torr. A set of external magnet coils was capable of producing an axially uniform magnetic field up to ~ 100 G.

The plasma density and temperature were measured using Langmuir probes (3 mm diameter discs), with densities on the order of $\sim 10^9$ cm^{-3} , and electron temperatures $T_e \approx 2$ eV. Potential measurements were made using emissive probes consisting of 0.1 mm diameter tungsten wire, about 3 mm in length, and heated to emission by a direct current. All probes were mounted on moveable shafts so that spatial profiles of densities and potentials could be obtained.

The fireballs and firerods were produced by biasing a disc electrode (diameter 3 to 5 cm) to a positive potential of 15–50 V relative to the grounded chamber wall, using a low-impedance DC power supply. The disc was coated on one side with a thin non-conducting ceramic material, and was located in the centre of the main chamber in front of a large viewing port through which photographs of the luminous structures could be taken.

3. Experimental results

The evolution of a 'fireball' into a 'firerod' is perhaps best illustrated by showing (in figure 2) a series of photographs taken at various values of the magnetic field strength. Photo #1 shows a stable fireball attached to a 3 cm diameter anode disc biased at +30 V, in a magnetic field-free argon plasma at a neutral gas pressure $\sim 10^{-3}$ Torr. When the magnetic field is increased to 9 G (photo #2) a deviation from the nearly spherical structure present in photo #1 is seen, although the 'fireball' remains stable. When the magnetic field is increased to ~ 19 G (#3) the fireball is no longer stable but rather a flickering glow is present around the

disc. With a further increase in B (#4) this unstable glow becomes more asymmetric, and begins to show a definite elongation along the magnetic field which is in the horizontal direction. When B is increased above some critical value (in this case, between 33 G and 41 G) the unstable glow is suddenly transformed into a stable firerod (photo #5) that is clearly aligned along the magnetic field. When the magnetic field is increased above 41 G the length of the firerod increases (photos 6–8). It is useful to compare the typical gyro radii of electrons and ions at a few values of B . For $T_e = 2.0$ eV and $T_i = 0.2$ eV, we find that for $B = 30$ G, $r_e \sim 1$ mm and $r_i \sim 10$ cm. Thus when $B = 10$ G, the electrons are already substantially magnetized and it is reasonable to expect a distortion of the fireball. On the other hand, the ions are only weakly magnetized even at the largest values of B shown.

The type of qualitative information obtained from figure 2 can be supplemented with additional data (figure 3) showing the variation of the disc current with magnetic field, under conditions somewhat different from those of figure 2. For $B < 5$ G, a stable fireball is present. As B is increased, a sharp drop in the disc current occurs at $B \gtrsim 5$ G and persists up to B slightly in excess of 20 G. This drop of the current is associated with the type of unstable glow shown in figure 2 (#3). When B exceeds about 22 G, there is a sharp increase in disc current, accompanied by the appearance of a stable firerod. As B is increased still further the current decreases with (in this case) and associated *decrease* in the length of the firerod until, at about 64 G, the firerod is extinguished. If the magnetic field is then decreased, the firerod reappears at $B \sim 27$ G, and persists down to about 16 G where it is again extinguished. Similar hysteresis effects were observed previously (e.g. Merlino and Cartier 1984).

The electric potential profiles of the firerods were obtained from the emissive probe measurements. For a typical firerod, contours of constant plasma potential are shown in figure 4. The boundary of the firerod consists of a double layer with a potential drop larger than the argon ionization potential (~ 16 V). Ions from the ambient plasma are not energetic enough to penetrate the double layer so that the ion population within the firerod must be generated inside the firerod by the electrons which are energized as they pass through the double layer. Langmuir probe measurements indicate that the plasma density inside the firerod is higher (on average by a factor of two or more) than in the surrounding plasma. The plasma density is not uniform within the firerod.

The length of the firerods was determined from axial profiles of the potential. Figure 5 shows a series of potential profiles for fixed values of the neutral gas pressure and of the disc voltage, V_{disc} , and for several values of the magnetic field. For this set of parameters the length of the firerod increases as B is increased. From this type of measurement we can construct the plot of figure 6 which shows the variation of the firerod length with B for various disc voltages. For high disc voltages the length generally increases with increasing B ; at

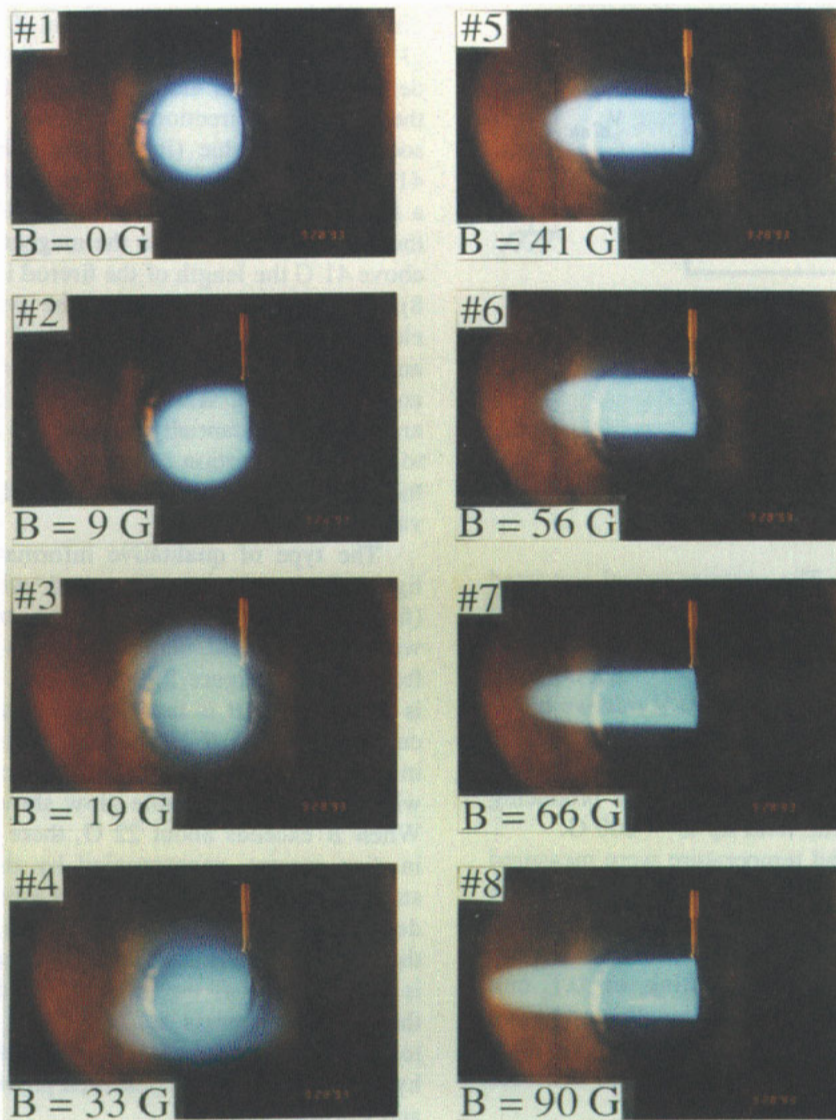

Figure 2. Colour photographs of fireballs and firerods formed in an argon plasma. Photos #1 and 2, stable fireballs; photos #3 and 4, unstable glow discharges; photos #5–8, stable firerods.

lower values of V_{disc} , however, it may, at first, increase slightly with B but shows the opposite behaviour at larger B values. Notice that figures 5 and 6 refer to two different neutral gas pressures (1.8 mTorr and 1.2 mTorr respectively) and, as it will shortly be seen, the firerod length is very sensitive to the neutral gas pressure in this pressure range.

In figure 7 we show a similar series of profiles for fixed magnetic field and disc voltage and three values of the neutral gas pressure. In the range of neutral gas pressures shown an increase in neutral gas pressure results in an increase in the length of the firerod. When the neutral gas pressure is increased beyond the values shown in figure 7, the tip of the firerod begins to retract back towards the disc. This effect is summarized in figure 8 which shows the variation of the firerod length with the neutral gas pressure, for several values of the disc voltage. This type of behaviour is somewhat different from that of the fireballs. In that case the

diameter of the fireball was always observed to decrease with increasing neutral gas pressure.

As indicated in figure 3, for a fixed neutral gas pressure and disc voltage there is a minimum value of B required to form a firerod, but there also exists a maximum B above which the firerod cannot be maintained. This effect is illustrated in figure 9, where the minimum and maximum values of B which can maintain a stable firerod are plotted against the neutral gas pressure. The shaded area indicates B - P pairs for which a stable firerod is present. One interesting feature of this diagram is the approximately linear relationship exhibited between the minimum B values and the argon neutral gas pressure (lower boundary of the plot). This feature has been investigated in more detail for firerods formed in both xenon (mass 131) and argon (mass 40) plasmas, and is shown in figure 10. Apparently the linear relationship between B and P also holds for the xenon firerods, although with a larger slope of the line

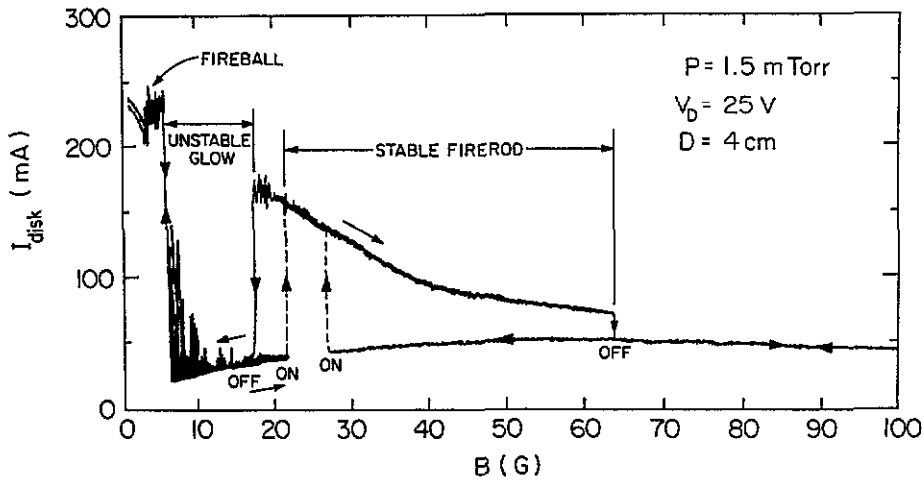

Figure 3. The I - B characteristic of a 4 cm disc in an argon plasma at a neutral gas pressure of 1.5 mTorr. Various stages in the evolution of a fireball and firerod are indicated.

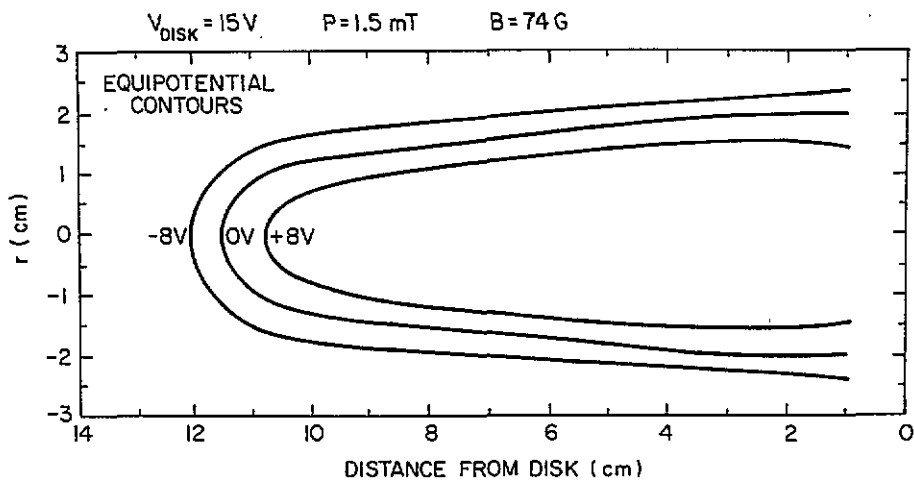

Figure 4. Electric potential contours of a firerod formed in argon. The contours were obtained from emissive probe measurements.

and some deviation from it at the lower values of B . This B - P relationship, we suspect, is an indication that the formation of a firerod requires a certain degree of magnetization of the ion species. Some further experimental evidence of the effect of the magnetic field on the ions is given in figure 11, where B - P plots are shown for argon firerods formed using discs of 3.2 cm and 5.0 cm diameter.

4. Discussion of the experimental results and comparison with a numerical model

4.1. Experimental results

The approximately linear relationship between the critical B field for firerod formation and neutral gas pressure is, we believe, an indication that the magnetic field is providing some influence on the confinement of the ions within the structures. The ion balance within

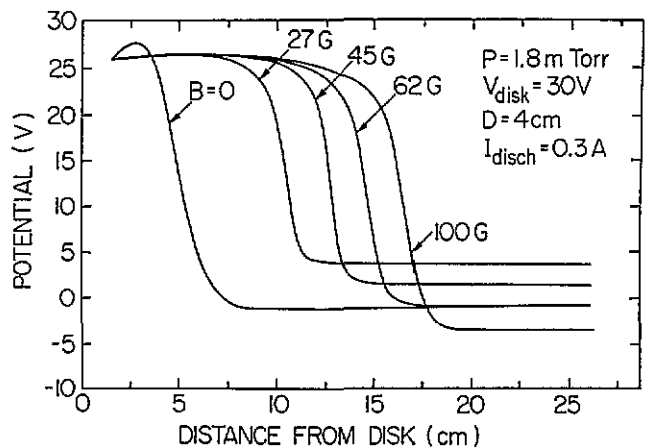

Figure 5. Profiles of potential taken along the axis of a firerod, for various magnetic field strengths.

the firerod is determined by ionization of the neutral gas by electrons which have been energized on passing

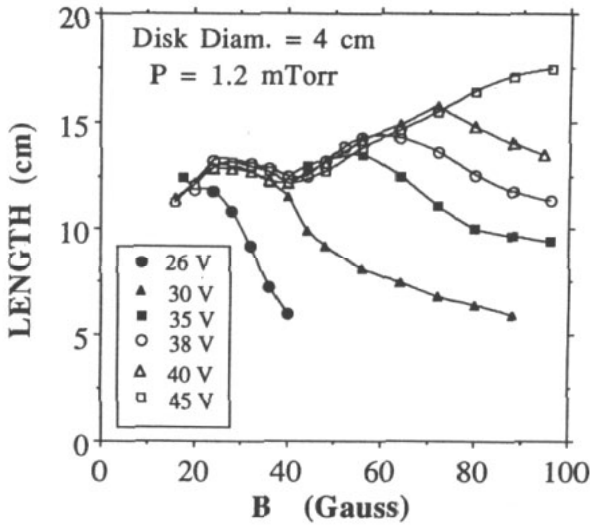

Figure 6. Firerod length against magnetic field strength for several values of the disc voltage. For the lower disc voltages, the length initially increases with B , then decreases with increasing B .

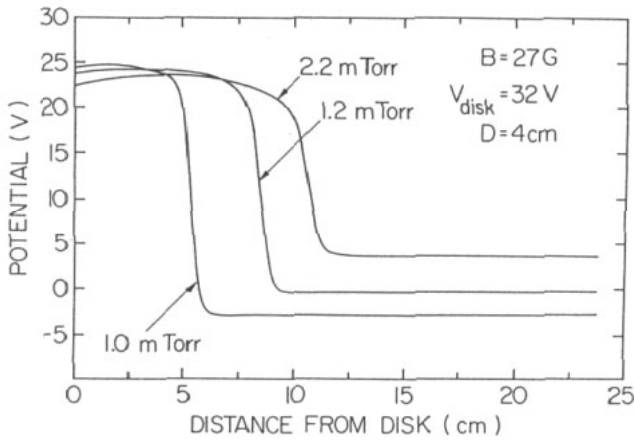

Figure 7. Profiles of potential taken along the axis of a firerod, for three values of the neutral gas pressure. In the range of parameters shown, the firerod length increases with pressure. Note also, that the potential drop across the double layer changes with neutral gas pressure.

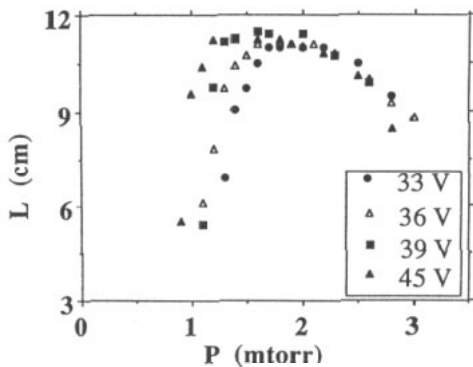

Figure 8. Firerod length against neutral gas pressure, for various disc voltages.

through the double layer boundary and by ion losses through the boundary. The ion losses may occur either through the front end of the firerod or through the cylindrical boundary (side losses). The magnetic field

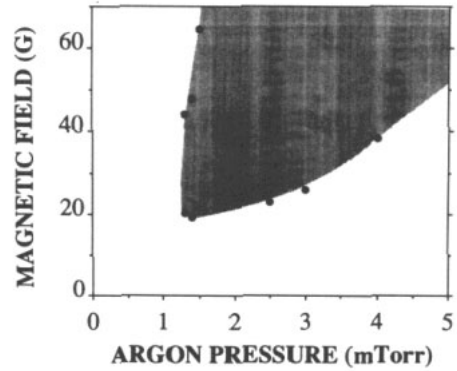

Figure 9. Firerod B - P stability diagram. Stable firerods could only be formed for B - P pairs within the shaded area.

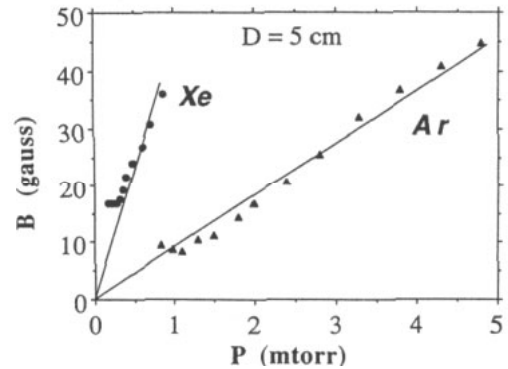

Figure 10. Minimum magnetic field strength to form a stable firerod against neutral gas pressure, for xenon and argon plasmas.

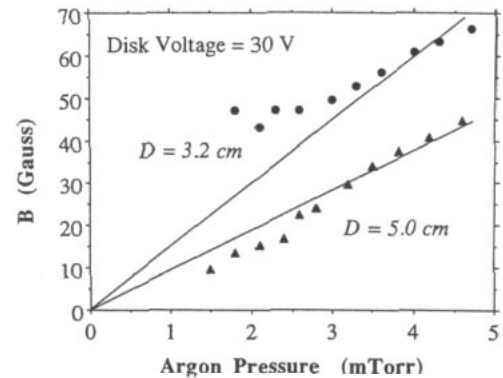

Figure 11. Minimum magnetic field strength to form stable firerods against argon neutral gas pressure for a 3.2 cm disc and a 5.0 cm disc.

may have some effect on these side losses, since the ions must cross magnetic field lines to exit the cylindrical firerod boundary. For the magnetic fields used in these experiments, and for argon ions with temperatures in the 0.02–0.2 eV range, the ion gyro radius was ~ 1 –10 cm. Thus since the firerods have diameters (depending on the disc size) in the 3–5 cm range, it is not unreasonable to expect that the B field will have some influence on the ion losses. This conclusion seems to be supported by figure 11 which shows that when the larger diameter disc is used, the firerods can be formed at lower magnetic field strengths.

The linear relationship exhibited between B and P in figure 10 can be understood if we assume that for stable firerod formation a certain degree of magnetization of the ions is required so that the ratio of the ion gyrofrequency to the ion neutral collision frequency, $\omega_{ci}/\nu_{in} \sim K$, where K is a constant of order 1. Writing $\omega_{ci} = eB/m_i$, and $\nu_{in} = N\sigma_{in}\nu_{i,th}$, where e is the elementary charge, m_i the ion mass, N the neutral gas density, σ_{in} the ion neutral collision cross section, and $\nu_{i,th} = \sqrt{kT_i/m_i}$ (T_i = ion temperature) we find that B and N are related as

$$B = \frac{K}{e}(m_i k T_i)^{1/2} \sigma_{in} N. \quad (1)$$

Thus, the slope of a B - N plot is given by $(K/e)(m_i k T_i)^{1/2} \sigma_{in}$. Values of the slope, in terms of the parameter K , for the xenon and argon plasmas were computed using an ion temperature of 0.1 eV and ion-neutral charge exchange cross sections of $\sigma(\text{Ar}^+-\text{Ar}) = 7 \times 10^{-19} \text{ m}^2$, and $\sigma(\text{Xe}^+-\text{Xe}) = 1.4 \times 10^{-18} \text{ m}^2$. For xenon the calculated slope is 157 K (G-mTorr $^{-1}$), and for argon 43 K (G-mTorr $^{-1}$). The measured slopes were 50 and 10 G-mTorr $^{-1}$ for xenon and argon respectively. A comparison of the calculated and measured slopes indicates that $K \sim 0.2$ - 0.3 . In addition to examining the actual values of the slopes we can also compare their ratios. The ratio of the calculated slope for xenon to that for argon is four, whereas the measured slopes have a ratio of five. This sample exercise seems to support the conclusion that a certain degree of magnetization of the ions is required for the formation of the firerods.

Next we present a simple model which might explain some features of the steady state behaviour of the firerods. In particular, we would like to understand how the length of the firerod depends on either the neutral gas pressure (see figure 8) or magnetic field strength (see figure 6).

4.2. Numerical model

This model is based on the idealized depiction of a firerod shown in figure 12. We take the firerod to be cylindrical in shape, with a length L and a circular cross section of radius R . The cylindrical boundary of the firerod is parallel to the magnetic field. Any electron which passes across the firerod boundary is energized so that it is capable of ionizing any neutral gas atoms with which it may collide. The model is then a statement of balance between ion production due to these energized electrons and ion losses through the boundary of the firerod. Note that (i) ions from the surrounding plasma cannot enter the firerod, and (ii) ions produced within the firerod cannot be collected by the disc, since experimentally we know that the potential within the firerod is always less (by at least a few volts) than the disc voltage.

In the model we take all particle fluxes to be spatially uniform, but we distinguish particles entering (or leaving) the firerod through the circular tip, from particles entering (or leaving) through the cylindrical boundary. The influence of the magnetic field appears in

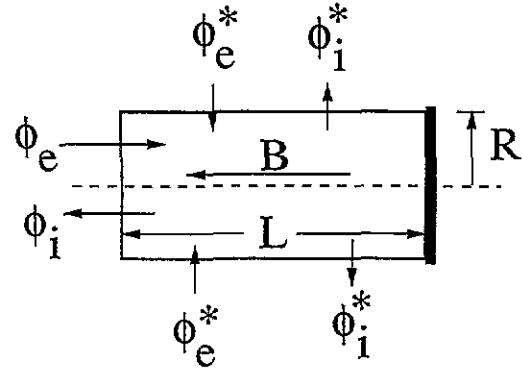

Figure 12. Schematic of a firerod used in the development of the numerical model.

the expressions for the electron and ion fluxes through this cylindrical boundary. As we shall see shortly, they are modelled in a purely phenomenological way.

If ϕ_e (cm $^{-2}$ s $^{-1}$) is the electron flux through the circular boundary, and ϕ_e^* (cm $^{-2}$ s $^{-1}$) is the electron flux entering through the cylindrical boundary, then the number of ions produced per second by ionization within the firerod is given by

$$\phi_e \pi R^2 N \sigma L + \phi_e^* 2\pi R L N \sigma L/2 \quad (2)$$

where N is the neutral particle density, σ is the electron impact ionization cross section evaluated at the energy of the accelerated electrons. The quantity $N\sigma L$ is the ratio of the total path length available for ionization to the ionization mean free path, and thus represents the probability for ionization. The second term in equation (2) is the contribution to ion production by electrons entering through the cylindrical boundary, and we have used an average path length of $L/2$ for these electrons.

The ion losses are expressed in terms of the flux ϕ_i (cm $^{-2}$ s $^{-1}$) of ions leaving the firerod along the magnetic field (through the circular end), and a flux ϕ_i^* (cm $^{-2}$ s $^{-1}$) of ions leaving through the cylindrical boundary. The total number of ions lost per second can then be written as

$$\phi_i \pi R^2 + \phi_i^* 2\pi R L. \quad (3)$$

Next, we introduce the expressions for ϕ_e^* and ϕ_i^* :

$$\phi_e^* = a \eta^\alpha b^{-\beta} \phi_e \quad (4a)$$

$$\phi_i^* = f \eta^\gamma b^{-\delta} \phi_i \quad (4b)$$

where $\eta = N/N_0$, $b = B/B_0$, and a , f , α , β , γ , and δ , are left as free parameters. The parameter a determines what fraction of the electron flux enters the firerod through the cylindrical boundary, whereas the parameter f is a measure of the fraction of ions which exit the firerod through the cylindrical boundary. N_0 and B_0 are the normalization constants for the neutral gas density and magnetic field respectively. We have taken $N_0 = 3 \times 10^{13} \text{ cm}^{-3}$ (corresponding to a neutral gas pressure of 1 mTorr). The parameter B_0 is actually chosen implicitly by the value for a (in equation 4(a)) in the sense that, for the range of magnetic fields used in

the experiments we expect that the cross-field electron flux should be consistent with classical diffusion. The neutral gas density and magnetic field dependencies of the fluxes in equation (4) are thus intended to model diffusion across the B field due to collisions with neutral particles; the degree of magnetization being reflected in the exponents β and δ .

One aim of this model is to obtain an expression for L , the length of the firerod, as a function of either neutral gas pressure or magnetic field strength. We insert the expressions (4a) and (4b) into equations (2) and (3) and then equate the ion production to the ion loss. We further assume that the fluxes ϕ_i and ϕ_e obey the Langmuir condition

$$\frac{\phi_e}{\phi_i} = \sqrt{\frac{m_i}{m_e}} \quad (5)$$

and, thus, obtain the equation

$$EL^2 + FL + G = 0 \quad (6)$$

where

$$E = a\eta^{\alpha+1}b^{-\beta}N_0\sigma \quad (7a)$$

$$F = R\eta N_0\sigma - 2\sqrt{\frac{m_e}{m_i}}f\eta^\gamma b^{-\delta} \quad (7b)$$

and

$$G = -\sqrt{\frac{m_e}{m_i}}R. \quad (7c)$$

Equation (6) has been solved numerically for L , for various combinations of the parameters a , f , α , β , γ , and δ . One important additional input to this calculation is the variation of the ionization cross section with electron energy. As shown in figure 7, the double-layer potential drop is a function of the neutral gas pressure. Since the electron energy within the firerod is determined by this potential drop we need to include this information in the calculation, because at these energies the cross section is strongly energy dependent.

In figure 13 we give an example of the calculation of the firerod length against the neutral gas pressure for various values of the normalized magnetic field b . The essential points to be taken from this calculation are that: (1) we are able to simulate firerods with lengths comparable to those observed in the experiments at neutral gas pressures in the same general range and (2) the calculated dependence of the firerod length on neutral gas pressure is of the same type as seen experimentally (compare figures 8 and 13).

The electron diffusion is treated as classical (N/B^2 dependence); the relatively low value of the parameter a (0.0001) indicating a small contribution to ionization within the firerod from electrons which enter it across B . On the other hand, the value of f (0.8) indicates that the ion losses along and across B are comparable, the value of $\delta = 0.1$ reflecting a weak dependence on B , of the transverse ion flux.

From curves of the type shown in figure 13, we can also construct curves of L against b at a fixed neutral

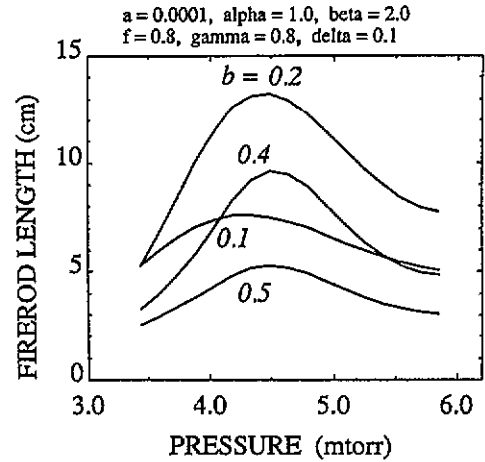

Figure 13. Results of the numerical model. The firerod length against neutral gas pressure for normalized magnetic field strengths of 0.1, 0.2, 0.4, and 0.5.

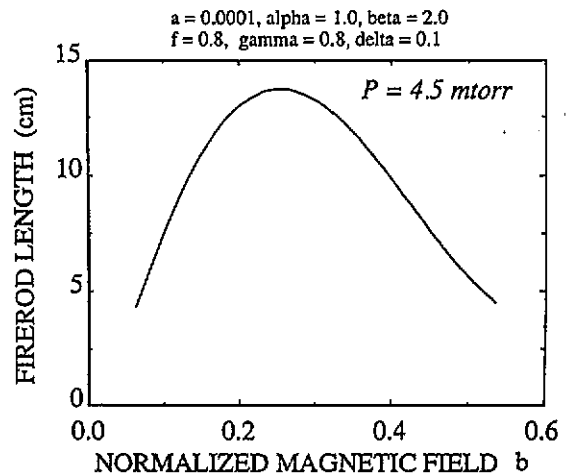

Figure 14. Calculated firerod length against normalized magnetic field strength for a neutral gas pressure of 4.5 mTorr. This plot was constructed from numerical results some of which appear in figure 13.

gas pressure, as shown in figure 14. The same general trend of L against B , as seen in figure 6, is obtained.

In assessing the results of this numerical model one needs to keep in mind that it was intended to be no more than a first step to obtain some understanding of the behaviour of the firerods. Several assumptions in the model were made for the sake of simplicity, although they do not correspond to the actual situation: for instance, the assumptions of uniform density within the firerod or that of a magnetic field everywhere tangent to the firerod cylindrical surface. In addition, the possible role of the $E \times B$ plasma rotation along most of the firerod boundary was neglected. The presence of plasma rotation in toroidal devices has been associated with the improvement of plasma confinement, and in the present experiments a similar enhancement may be suggested by the high plasma density inside the firerod. On the other hand, the notion of rotation of the plasma ions may not be quite applicable in our case, even at the largest B fields, the ion gyroradius ($r_i \sim 5$ cm) is considerably larger than the transverse size (~ 1 cm) of the region of high E field.

5. Concluding remarks

In this paper we have presented experimental results showing the effect of a uniform magnetic field on the formation of firerods—elongated anode double layers. This study was a direct extension of our previous work on spherical anode double layers in unmagnetized plasmas (Song *et al* 1991). As might be expected, the presence of the magnetic field substantially complicates the situation and, in fact, our results show that stable firerods could only be formed within the B - P shaded area of figure 9. Some magnetic field is necessary to convert a fireball into a firerod, but the firerod cannot be maintained if the field is too strong. The minimum B field seems to be connected to the requirement of a certain degree of magnetization of the ions, although over the entire range of stable firerod formation the ions are only weakly magnetized.

We have made a crude first attempt at modelling the firerods by extending the simple ion balance model used to understand the behaviour of spherical fireballs (Song *et al* 1991). In the case of these fireballs, the model was useful in understanding how the neutral gas pressure controlled the radius of the structures, and we were able to obtain numerical values of the radius which were close to the observed ones. The present firerod model must also account for particle fluxes through the cylindrical boundary of the structures. A phenomenological approach was taken to include the magnetic field and neutral gas pressure dependence of these fluxes. The model seems to account for some of the most obvious behaviour of the firerods, namely the

dependence of their length in neutral gas pressure and magnetic field.

Finally, we note that the effect of a magnetic field on anode double layers is relevant to the applications discussed in our previous paper (Song *et al* 1991), e.g. plasma contactors, since such devices must operate in the geomagnetic field.

Acknowledgments

We thank the referee for pointing out the possible importance of plasma rotation in enhancing the ion confinement within the firerods (section 4).

This work was supported by the US Office of Naval Research and NASA.

References

- Andersson D 1981 *J. Phys. D: Appl. Phys.* **14** 1403
- Cartier S L and Merlino R L 1987 *Phys. Fluids* **30** 2549
- Cook D L and Katz I 1988 *J. Spacecr. Rockets* **25** 132
- Fujita H, Yagura S and Matsuo K 1984 *Phys. Fluids* **27** 2948
- Merlino R L and Cartier S L 1984 *Appl. Phys. Lett.* **44** 33
- Plamondon R, Teichmann J and Torvén S 1988 *J. Phys. D: Appl. Phys.* **21** 286
- Sanduloviciu M and Popa G 1993 *Proc. 4th Symp. on Double Layers and other Nonlinear Potential Structures in Plasmas* ed R W Schrittwieser (Singapore: World Scientific) p 114
- Song B, D'Angelo N and Merlino R L 1991 *J. Phys. D: Appl. Phys.* **24** 1789
- 1992a *J. Phys. D: Appl. Phys.* **25** 938
- Song B, Merlino R L and D'Angelo N 1992b *Phys. Scr.* **45** 395
- Torvén S and Andersson D 1979 *J. Phys. D: Appl. Phys.* **12** 717